

# LED Street Lights

Eco-LED™ series

Architectural highlights in LEDs

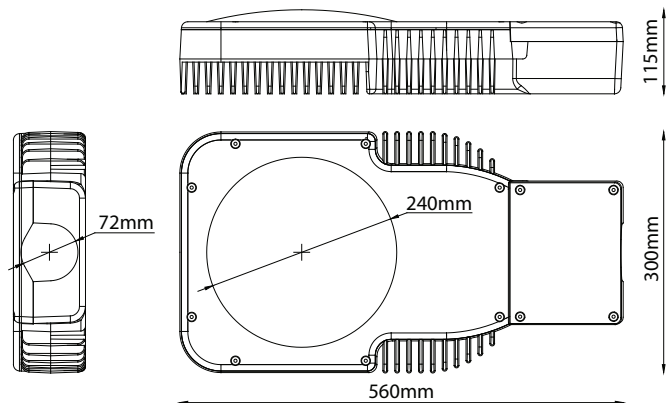

### Features:

- These new generation LED Street lamps will save on energy usage (up to 60%) and on maintenance costs
- They are available in power output increments from 60W to 240W
- High power factor and power efficiency with patented heat dissipation technology
- Semi-cut-off design with wide beam angle giving a huge lighting area
- IP65 rated with powder coating on cast alloy aluminium housing
- Colour Temperature ranges from 3000K to 7000K
- Save up to 60% on energy usage when compared to incandescent street lights
- Instant start and flicker free with even light distribution
- Maintenance free for up to 4 years with a life span of 50,000 hours



**LedFX LED street light comparison with high pressure sodium lights**

Product code	LED60	LED90	LED120	LED150	LED180	LED210	LED240
Leds in Watts	60W	90W	120W	150W	180W	210W	240W
Equivalent Sodium	150W	200W	250W	350W	450W	500W	600W

www.ledfx.com.au



# LedFX

All dimensions are approximate. The information provided in this brochure is representative of the actual products available at the time of printing. Due to our continuous product development, the designs and specifications depicted are subject to change without notice. Please confirm all particulars with your sales consultant prior to purchase. Each product is covered by a limited warranty. Full terms and conditions are available from your sales consultant. NeonGlo™, LedStar®, DicroLed™, SplashLite®, Luxstar® & EdgeLed™ are covered by one or more of the following patents: 2001100435/2002100441/2002100439 by Cgm Technologies Pty Ltd. © 2004.

9b Lakewood Blvd. Braeside VIC 3195  
 P: 03 9588 1282 F: 03 9588 2088  
 E: sales@ledfx.com.au