

EdgeLED™ Halo

Eco-LED™ series

Architectural highlights in LEDs

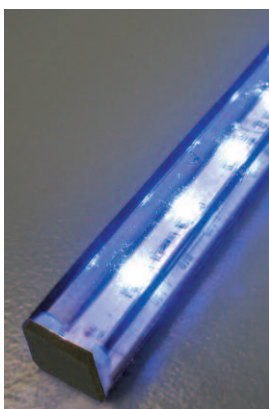

Features include:

- EdgeLED Halo is perfect for halo effects in clubs, hotels, restaurants or in domestic situations such as stair tread edging, Vanity lighting, bar fronts etc.
- Supplied in multiples up to 1.8m lengths
- Can be used in conjunction with any **LedFX** controller for fading/flashing effects
- Yellow, orange, red, green, blue, white and **full colour changing** versions are available
- Energy efficient, up to **90% reduction in energy consumption** compared to incandescent lights
- Units have continuous life span running **60,000 hours plus**
- **Environmentally friendly**, containing no mercury or sodium
- Solid state electronic light source (Light Emitting Diodes) means virtually no maintenance
- Very **easy to install** using safe extra low voltage 12 volts
- Low heat radiation and **no UV emissions**
- Moisture and impact resistant

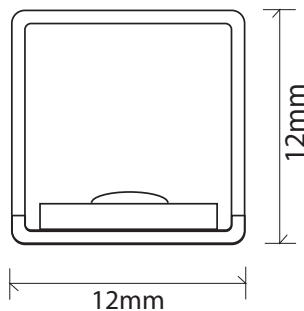

9b Lakewood Blvd. Braeside VIC 3195

P: 03 9588 1282 F: 03 9588 2088

E: sales@ledfx.com.au



LedFX

All dimensions are approximate. The information provided in this brochure is representative of the actual products available at the time of printing. Due to our continuous product development, the designs and specifications depicted are subject to change without notice. Please confirm all particulars with your sales consultant prior to purchase. Each product is covered by a limited warranty. Full terms and conditions are available from your sales consultant. NeonGlo™, LedStar®, DicroLed™, SplashLite®, Luxstar® & EdgeLed™ are covered by one or more of the following patents: 200100435/2002100441/2002100439 by Cgm Technologies Pty Ltd. © 2004.